

Rotary actuators - Gripper swivel models Pneumatic ARP... ARPEP Schwenkeinheiten/Greif-Schwenk-Module Pneumatic ARP....ARPEP

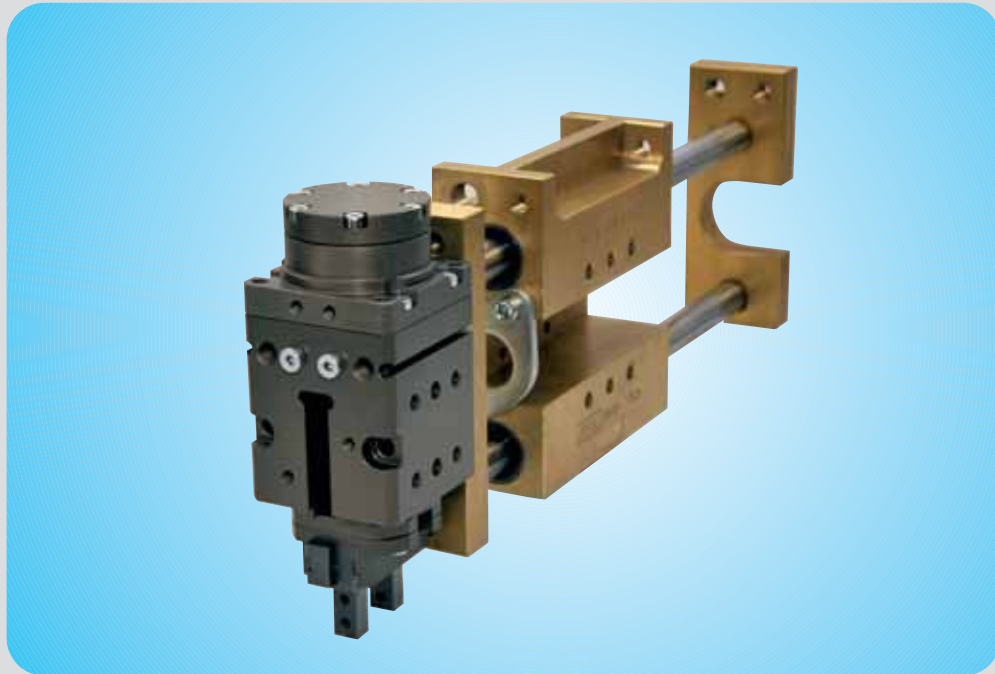

Technische Eigenschaften:

- Betriebsdruck: 3.5 bis 6.5 bar Greifer; 3 bis 8 bar Schwenkeinheiten
- Wiederholgenauigkeit: 0.09° Schwenkeinheiten/ 0.02 Greifer über 100 Schaltspiele
- Betriebstemperaturbereich von 5°C bis 60°C
- Endlagendämpfung hydraulische Stoßdämpfer auf Anfrage
- Endlagen feinjustierbar 2°
- Wirkprinzip:
Schwenkeinheiten: Schwenflügel
- Greifer: Keilhakenprinzip zwangsgeführt über schräge Ebene
- Material: Gehäuse aus hochfester Aluminiumlegierung hartbeschichtet, Funktionsteile aus gehärtetem Stahl
- Betätigung : pneumatisch über gefilterte Druckluft (10µm), trocken oder geölt
- Wartungsfrei: bis 1.5 Mio. Zyklen
- Einstellbare Zwischenposition
- Greifkraftsicherung auf Anfrage
- Schutzart: IP40 Greifer / IP 52 Schwenkeinheiten
- 24 Monate Garantie

Technical data:

- Range of operating pressure: 3.5 - 6.5 bar swivel 3 - 8 bar gripper
- Repeatability accuracy: 0.09° swivel / 0.02mm gripper over 100 cycles
- Operating temperature: from -5°C to 60°C;
- Damping upon request by shock absorber
- Operating principle:
swivel: rotor and piston drive
gripper: wedge-hook kinematic
- Housing material: high tensile hard-coated aluminium alloy, hard-anodized
- Material of functional parts: treated and /or ground steel
- Actuation: compressed air filtered (10 µm), dry or lubricated
- Maintenance: no maintenance required for the first 1.5 million cycles
- End positions without clearance
- Safety device on request
- Rating IP 40 gripper - IP 52 swivel
- Warranty 24 month

Rotary actuators - Gripper swivel models Pneumatic ARP... ARPEP Schwenkeinheiten/Greif-Schwenk-Module Pneumatic ARP...ARPEP

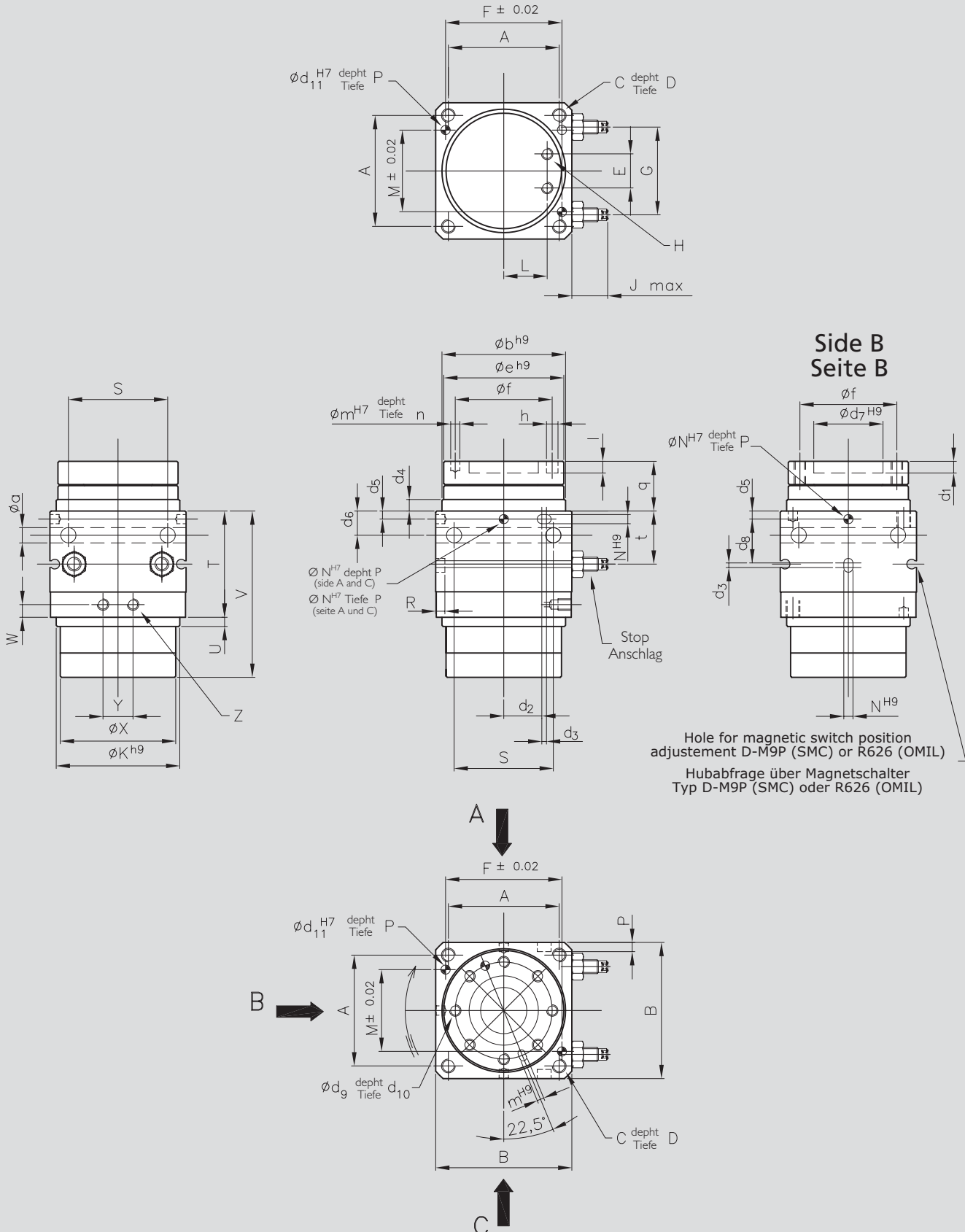

Rotary actuators - Gripper swivel models Pneumatic ARP... ARPEP Schwenkeinheiten/Greif-Schwenk-Module Pneumatic ARP...ARPEP

Type Typ	A	B	C	D	E	F	G	H	J	L	M	N	P	R	S	T	U	V	Z	Y	X	K
ARP 3	36	44	M4	5.5	13	36	24	M3	8.5	9	26	3	2.5	3	29	36	2	45	M5	11	35	42
ARP 7	41	50	M5	7	16	43	30	M5	10.5	11	31	4	3.5	3.5	36	44	3	58.5	M5	12	45	48
ARP 20	48	59	M6	7	16	48	38	M5	10.5	14.5	35	4	5	4	43	46	4	72	M5	13	50	53.5

Type Typ	a	b	d ₁	d ₂	d ₃	d ₄	d ₅	d ₆	d ₇	d ₈	d ₉	d ₁₀	d ₁₁	e	f	h	l	m	n	q	t	W
ARP 3	4.5	42	3	11	2	3	3	8	21	12.5	M4	7	3	41	30	5	5	3	3	15.5	17.1	6
ARP 7	5.5	48	4	13	2	4.5	3.5	10.5	26	16	M4	8	3	47	37	5	5	3	5	19	20.5	6
ARP 20	6.6	53.5	5	16	2	5	3.5	10.5	30	19	M5	10	4	52	42	5	5	3	5	21.5	23	5.5

Type	Feed torque at 6 bar (Nm)	Rotation 0°-180° without load in sec.	Air consumed in cm ³ at 6 bar for one cycle	Axial load A in N	Radial load CR in Nm	Mass Kg	Allowable kinetic energy J kgm ²
Typ	Drehmoment bei 6 bar (Nm)	Schwenkzeit 0°-180° pro zyklus (s)	Luftverbrauch (cm ³) bei 6 bar pro zyklus	Max. axiale Belastung A (N)	Max. radiale Belastung CR (Nm)	Masse Kg	Massen Trägheitsmoment (Kgm ²)
ARP 1	0.38	0.15	22	30	0.7	0.25	0.014
ARP 7	0.8	0.16	46	60	0.9	0.45	0.034
ARP 20	2.25	0.18	75	80	2.7	0.70	0.074

Sensor bracket code F8

Halterung für Näherungsschalter Version F8

Magnetic limit switch seat ØG
Bohrung für Näherungsschalter ØG

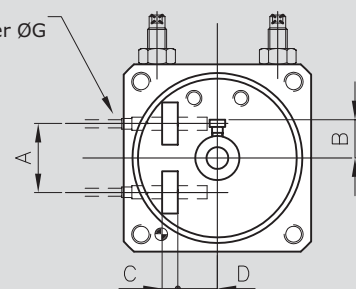

Type Typ	Type Typ	A	B	C	D	E	F	G
ARP 3	ARPEP 10	19	11	6	5.4	9	9.5	4
ARP7	ARPEP 16	24	14	8	6.75	10	9	5
ARP 20	ARPEP 20/25	24	14	8	8.75	13	9	5

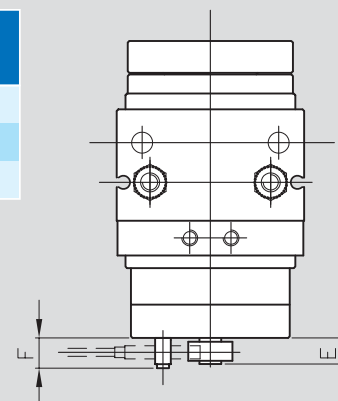

Rotary actuators - Gripper swivel models Pneumatic ARP... ARPEP Schwenkeinheiten/Greif-Schwenk-Module Pneumatic ARP...ARPEP

Type	A	B	C	D	E	F	G	H	J	L	M	N	P	R	S	T	U	V	Z	Y	X	K	W
ARPEP 10	34	37	M4	8	13	3	41	M3	19.6	9	25	3	4	37	8	63	2	10	6.5	10	35	5	4
ARPEP 16	41	47	M5	8	16	3	50	M5	20	11	31	4	5	47	9,5	78	2	8.5	8	12	45	13	4
ARPEP 20	48	54	M6	10	16	4	59	M5	25	14.5	35	5	6	50	11	101	3.1	3.1	16	13	50	28.4	4
ARPEP 25	48	66	M6	10	16	5	70	M5	25	14.5	35	6	8	50	14	107	6.3	6.3	20	25	50	25.3	4

Type	a	b	d	d ₁	d ₂	d ₃	d ₄	d ₅	d ₆	d ₇	d ₈	d ₉	d ₁₀	e	f	h	i	m	n	q	t	f ₁	f ₂	f ₃
ARPEP 10	7	11.2	4	M4	6	2	19.5	4	5.7	3	5	16.4	35.5	M2.5	12	34	10	4.5	4	17.9	23	18	5	22
ARPEP 16	8	14.9	5	M5	8	2	13	16	7	4	8	23.6	46.5	M3	15	42	15	5.5	2.5	30	29	22	12	28
ARPEP 20	11.5	16.3	8	M6	9	3	28	10	9	5	10	27.6	53	M4	20	51	20	6.5	6	45.9	36	26	6	28
ARPEP 25	15	19.3	10	M8	12	2	34	10	12	6	12	33.6	65	M5	25	63	20	8.5	4	42.8	42	27.5	8	31

Type	f ₄	f ₅	f ₆	f ₇	f ₈	f ₉	f ₁₀	h ₁	h ₂	h ₃	h ₄	h ₅	h ₆	h ₇	h ₈	h ₉	h ₁₀	h ₁₁	h ₁₂	h ₁₃	h ₁₄	h ₁₅	h ₁₆
ARPEP 10	16	33	5	7	M5	7	11.5	12	19.5	12	24	8.5	9.8	2.9	6	13.5	10	11.5	34	2.5	34	34	25
ARPEP 16	26	40	6	6.5	M6	6.5	19	10	24.2	15.2	30	10.5	12.5	3.5	8	5	24	15	43	3	43	41	31
ARPEP 20	46	6	10	M6	10	28	10	28.2	15.7	38	10.5	18	4.8	16.5	10	28	16.5	48	4	48	48	35	
ARPEP 25	22.5	54	8	12	M8	12	34	10	35	19.5	38	10.5	22.5	6.3	17	10	34	17	48	4	62	58	43

Type	Stroke for finger		Gripping force at 6 bar (N)		Air consumed for double stroke gripper (cm ³)	Recommended weight of part for transport (kg)		Approx time (s)		Max finger length / weight (Kg)
	code 1	code 2	code 1	code 2		code 1	code 2	open	closing	
ARPEP 10	2	3.5	30	16	0.45	0.15	0.08	0.03	0.03	25 / 0.015
ARPEP 16	3	5.5	94	54	1.85	0.45	0.27	0.04	0.04	32 / 0.04
ARPEP 20	5	8.5	150	86	4.8	0.75	0.43	0.05	0.05	42 / 0.08
ARPEP 25	7	10.5	200	140	8.7	1	0.7	0.05	0.05	52 / 0.18

Type	Feed torque at 6 bar (Nm)	Rotation 0°-180° without load (s)	Air consumed in cm ³ at 6 bar for one cycle	Allowable kinetic energy Jamm in (Kgcm ²)	CA (N)	MR (Nm)	MT (Nm)	Mass (Kg)
ARPEP 10	0.3	0.2	22	0.004	100	1	0.7	0.3
ARPEP 16	0.7	0.22	46	0.013	180	2.5	2	0.6
ARPEP 20	2	0.24	75	0.033	300	5	2.5	1.1
ARPEP 25	1.9	0.25	75	0.072	350	10	4	1.6

Transportable weight calculated with $\mu = 0.1$ and $f_s = 2$. With form-fit gripping the mass may be greater. The gripping force is the arithmetic sum of the individual forces created at the fingers at "l" mm distance at 6 bar Allowable load data CA, MR, MF see the following page (134)

Empfehlung für max. Werkstückgewicht gerechnet mit $\mu = 0.1$ $f_s = 2$. Bei Fomschluss sind größere Massen möglich. Die Greifkraft ist die arithmetische Summe der an den Greifbacken auftretenden Einzelkräfte im Abstand "l" in mm bei 6 bar - Eigenmasse in Kg - Maximal zul. Kräfte und Momente am Finger seite 134

Rotary actuators - Gripper swivel models Pneumatic ARP... ARPEP Schwenkeinheiten/Greif-Schwenk-Module Pneumatic ARP...ARPEP

Type	Version	For sensor bracket indicate code F8	For shock absorbers indicate code V3	Indicate direction of rotation	Indicate gripper code 1 or 2	For safety device indicate MC or MA
Typ	Version	Induktive Abfrage Vers. F + Ø	Für Stoßdämpfer Ausführung Vers. V+Typ	Schwenk Richtung Ausführung	Version 1 oder 2	Für federgestützte Greifkraftsicherung MC oder MA
ARPEP 16	CA	F8	V3	RO	C1	MC

- Version CA 180° code CA - 90° Code CB
- Direction of rotation: "clockwise" code RO
"anticlockwise" code RA
- Technical data safety device to preserve gripping force see gripper PEP
- Version: CA Schwenkwinkel 180° - CB Schwenkwinkel 90°
- Schwenkrichtung: im Uhrzeigersinn code RO – gegen de Uhrzeigersinn code RA
- Technische Eigenschaften Maßangaben für Greifer mit Greifkraftsicherung siehe Greifer PEP

Allowed load data ARPEP

Maximal zul. Kräfte und Momente am Finger ARPEP

Type	CA (N)	MR (Nm)	MT (Nm)
Typ			
ARPEP 10	100	1	0.7
ARPEP 16	180	2.5	2
ARPEP 20	300	5	2.5
ARPEP 25	350	10	4

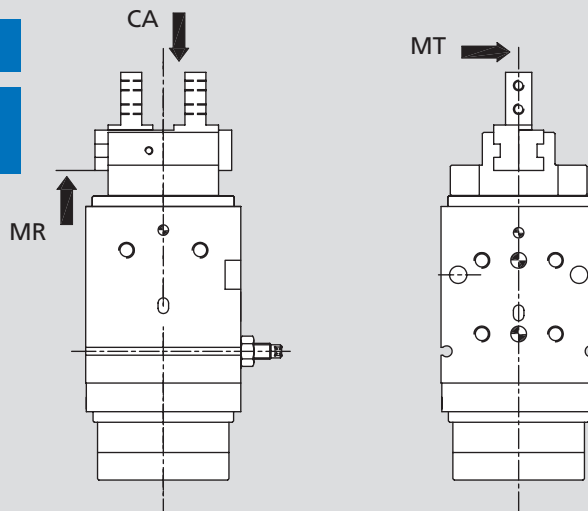

Shock absorber code V3

Stoßdämpfer Version 3

Type	Type	J
Typ	Typ	
ARP 3	ARPEP 10	16
ARP 7	ARPEP 16	16
ARP 20	ARPEP 20	18
/	ARPEP 25	18

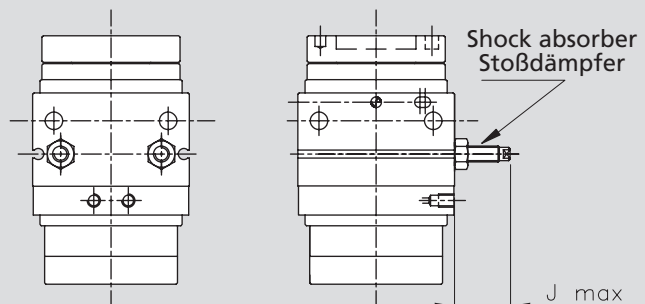

Combination ARPEP - AL

kombination ARPEP - AL

Type	Type
Typ	Typ
ARPEP 10	AL 08
ARPEP 16	AL 12 / AL 16
ARPEP 20	AL 16
ARPEP 25	AL 20

